

**CHEVRON DETAIL
FOR SPEED HUMP**

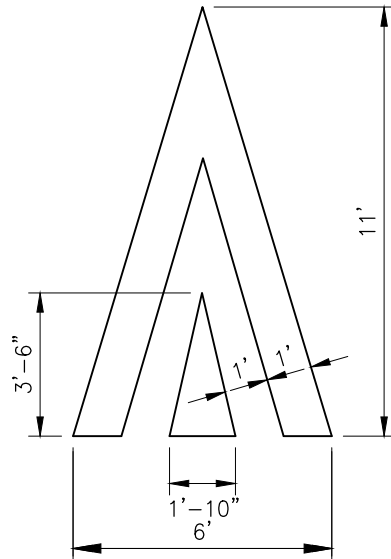

**CHEVRON DETAIL
FOR SPEED TABLE**

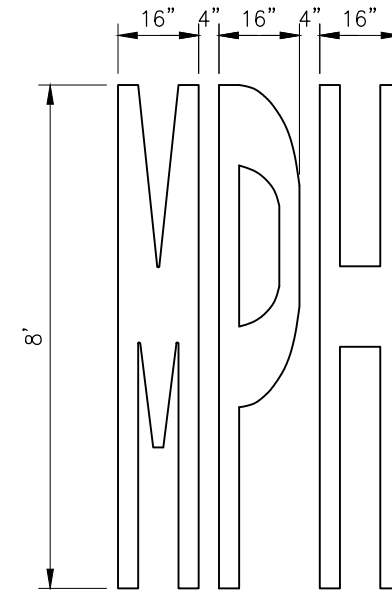
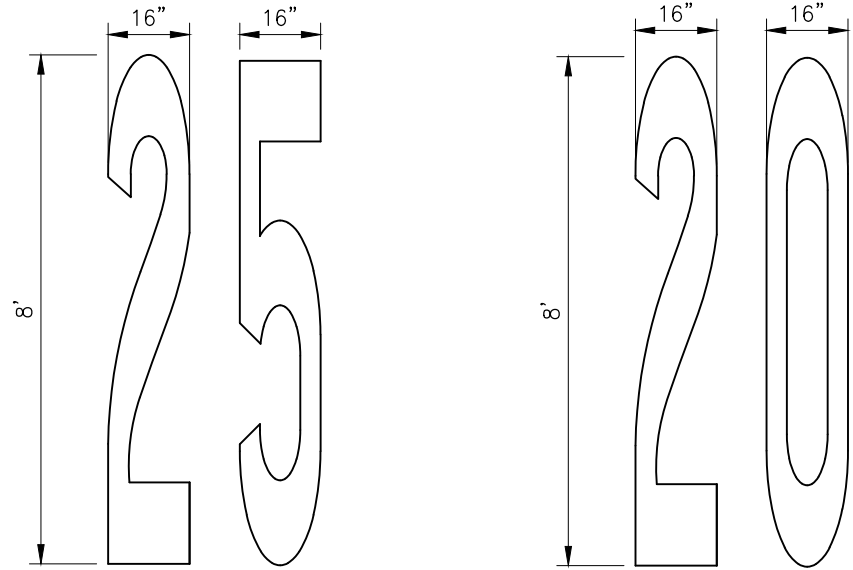

SPEED LIMIT MARKINGS

NOTES:

1. ALL PAVEMENT MARKINGS SHALL BE PRE-FORMED TYPE B HEAT FUSED THERMOPLASTIC (125 MILS.).
2. SPEED LIMIT PAVEMENT MARKINGS SHALL BE INSTALLED ONLY AT THE WRITTEN DIRECTION OF THE PUBLIC WORKS DIRECTOR.
3. 20 MPH SPEED LIMIT PAVEMENT MARKING IS FOR PARK USE ONLY.
4. ALL CHANNELIZATION (OR PAVEMENT MARKINGS) SHALL BE LAID OUT WITH SPRAY PAINT AND APPROVED BEFORE FINAL INSTALLATION. APPROVALS SHALL REQUIRE ADVANCE NOTICE OF THREE WORKING DAYS TO HAVE FIELD LAYOUT APPROVED.

NOT TO SCALE



**CITY OF DES MOINES
PUBLIC WORKS DEPARTMENT**

ENGINEERING SERVICES
21650 11TH AVENUE SOUTH
DES MOINES, IA 50319



PAVEMENT MARKINGS

DM.F2.4

REVISED: 02/23